

## URBAN DESIGN COMMITTEE

APPLICATION NUMBER Urban Design Record #UDR26045  
APPLICATION TYPE Advisory review & Final Action  
ADDRESS/LOCATION 701 S 10<sup>th</sup> St.  
HEARING DATE May 05, 2026  
ADDITIONAL MEETINGS -  
APPLICANT Elizabeth Elliot, [elizabeth.elliott@lincoln.ne.gov](mailto:elizabeth.elliott@lincoln.ne.gov)  
STAFF CONTACT Arvind Gopalakrishnan, 402-441-6361, [agopalakrishnan@lincoln.ne.gov](mailto:agopalakrishnan@lincoln.ne.gov)

**RECOMMENDATION: APPROVAL**

### Project Description

Located between 9th and 10th streets, and between G and H streets, the newly planned Multi-Modal Transportation Center for Lincoln Transportation and Utilities-StarTran will bring a new transit hub to Downtown Lincoln.

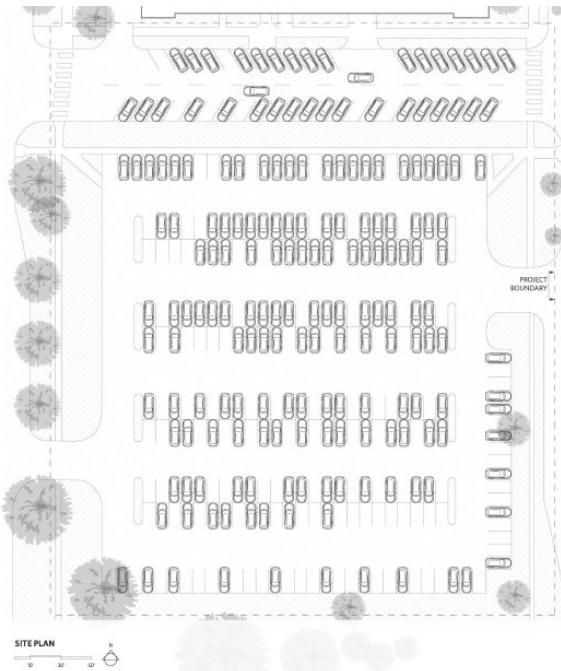

Existing Site Plan



Proposed Site Plan

## Site Design + Operations

This proposal will place a new operations building just south of the county/city building, which will include customer service windows, a large public waiting space, and administrative spaces for LTU staff. The operations building will be separated from the County-City Building by a pedestrian courtyard space – replacing the existing H street on this block. To the west of the new operations building, a large bus loading/unloading zone comprising 19 bus parking bays will facilitate bus transfers for StarTran passengers.

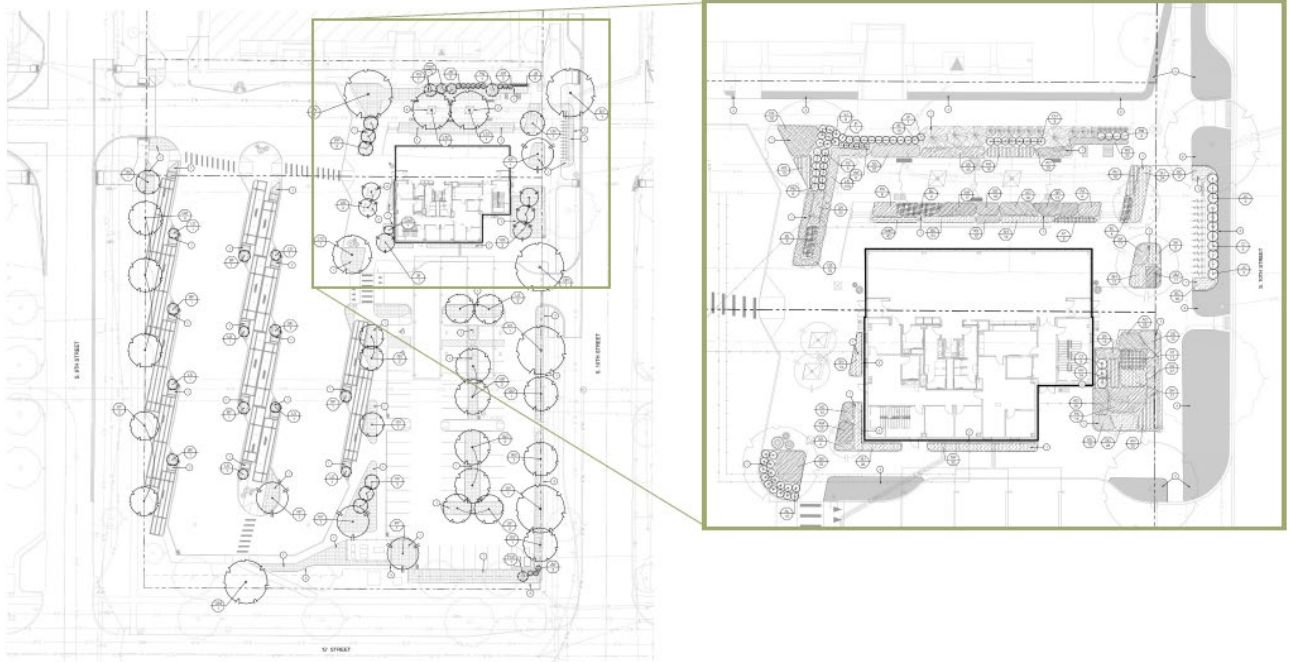

**HDR** olsson Star Tran Multi-Modal Transit Center



**HDR** olsson Star Tran Multi-Modal Transit Center

The development of this project focuses on the idea that the intervention of a transit facility – a project typology that typically requires large amounts of paved area – should strive to feel more like a park than a parking lot. The design supports this idea by infusing outdoor spaces with flora throughout, while minimizing pavement where possible.

Further, this project aims to meet aggressive building performance goals to minimize its impact on our environment. A planned geothermal well-field will provide natural heat exchange for the mechanical system, and the bus canopies incorporate photovoltaic panels, which will generate electricity on site.

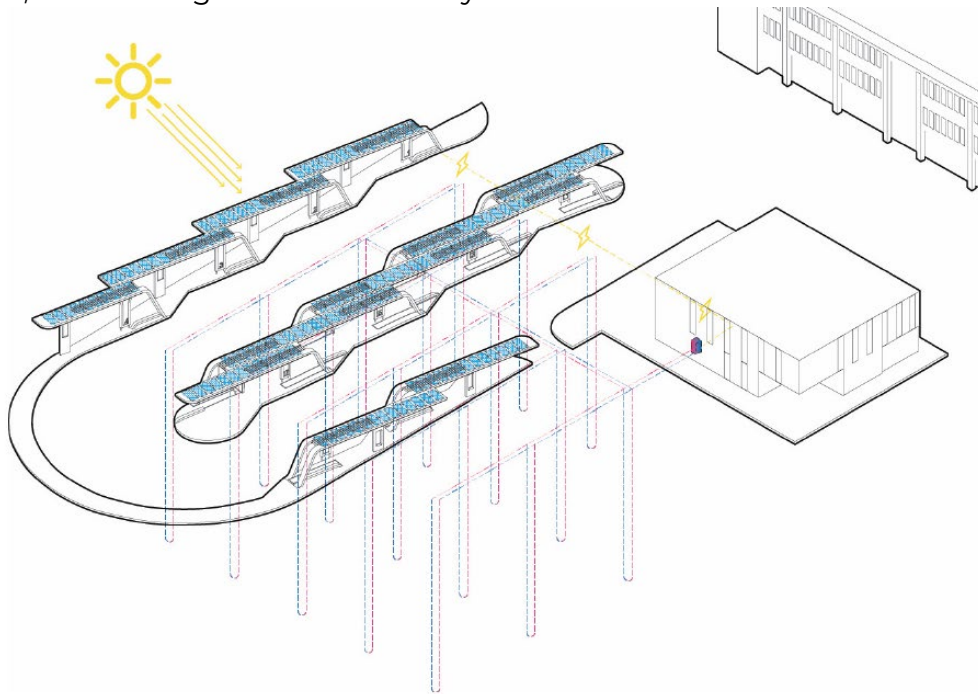

The operations building is intended to sit somewhat quietly and respectfully next to its nearest neighbor, the County-City Building on the north, and a residential area on the south.



HDR olsson Star Tran Multi-Modal Transit Center

### Proposed envelope + Material Palette

Planned to be clad in ultra-high-performance concrete (UHPC) panels, the color of the building will remain neutral and light, respecting the palette of the seat of local government.

#### Architectural Material Palette

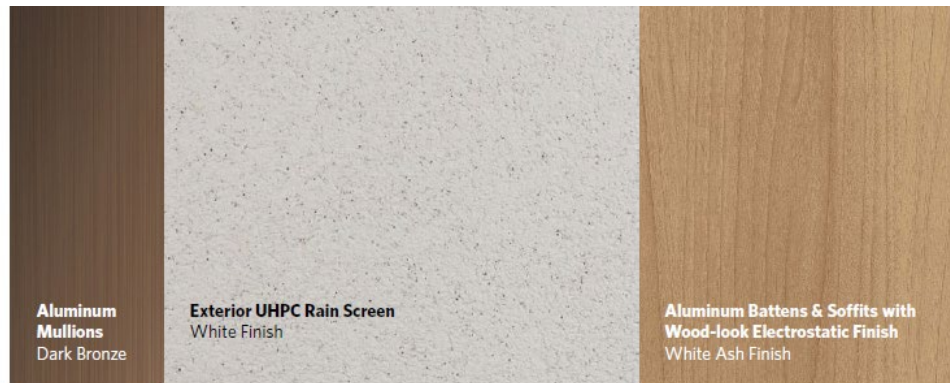

**Aluminum Mullions**  
Dark Bronze

**Exterior UHPC Rain Screen**  
White Finish

**Aluminum Battens & Soffits with Wood-look Electrostatic Finish**  
White Ash Finish

Fenestration is organized in vertical patterns, again borrowing from the simple formal motifs of the building's context.

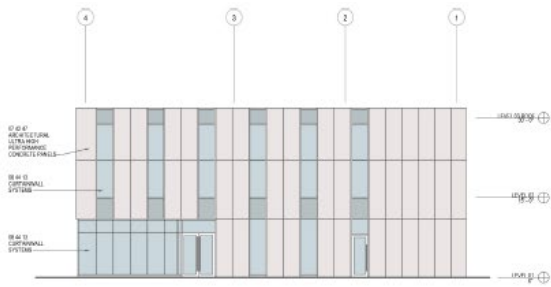

**West Elevation**



**South Elevation**

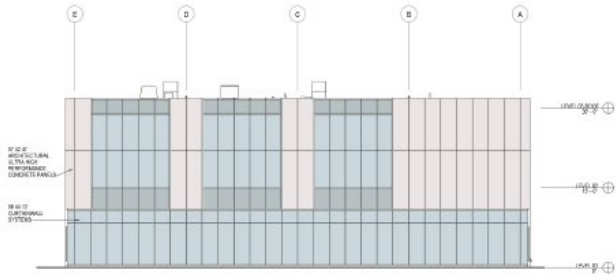

**North Elevation**



**East Elevation**

## Architectural features

Exterior soffits as well as screening elements on the bus canopies plan to utilize a wood-look aluminum material to add a touch of naturally inspired materiality while maintaining strong durability that transit facilities typically require.

The canopies, meanwhile, reinforce the neutral color palette, but also bring in additional warmth with signage elements that are clad in a bronzed aluminum panel. The canopies are situated askew from the operations building, and instead align to the saw-toothed bus loading bays, which are positioned to maximize efficiency of both pedestrian and bus traffic on site.



By decommissioning H Street on this block, the site plan allows for increased pedestrian space while maintaining the necessary flow of vehicular and pedestrian movement on the site. In biasing the position of built elements to the north, this solution maintains a healthy buffer along the southern property line to the residential neighbors in the area. The site design includes bike parking, a BikeLNK station, scooter parking, and a small number of public parking for visitors to the facility and safe rideshare drop-offs and pick-ups.



## Site furniture, amenities, and wayfinding

Seating elements

[https://linclanc.sharepoint.com/sites/PlanningDept-Boards/Shared Documents/Boards/UDC/Agendas/2026/May 5 Web PDF's/UDR26045\\_MMTC\\_ITEM2.docx](https://linclanc.sharepoint.com/sites/PlanningDept-Boards/Shared Documents/Boards/UDC/Agendas/2026/May 5 Web PDF's/UDR26045_MMTC_ITEM2.docx)



### Bike & scooter storage

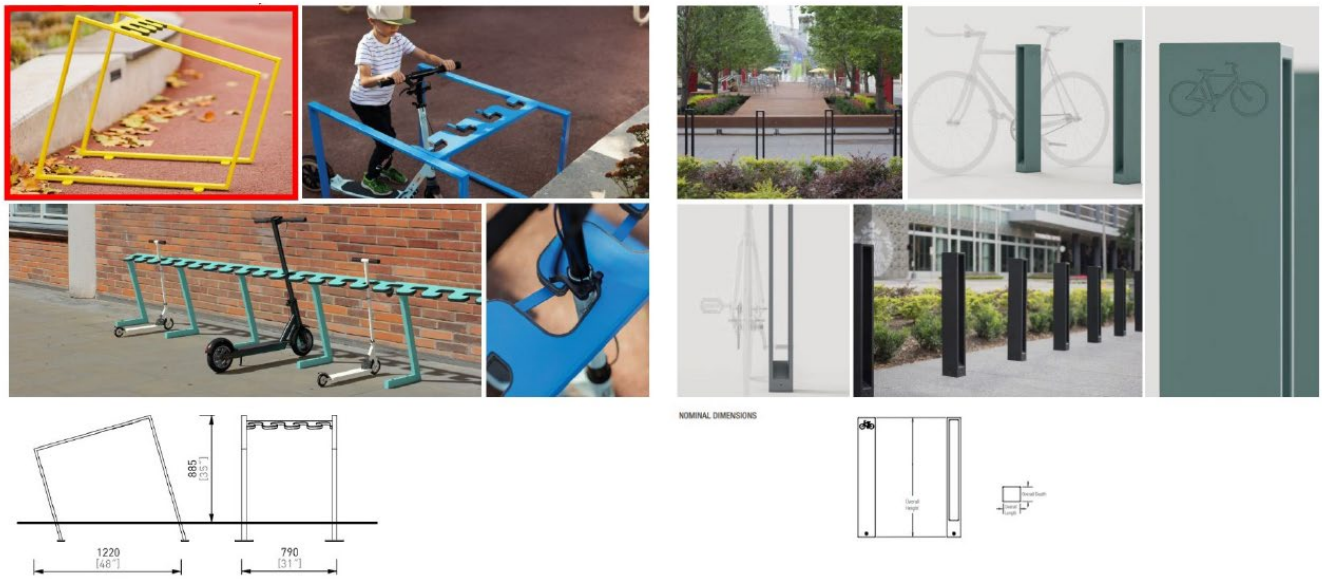

### Screening

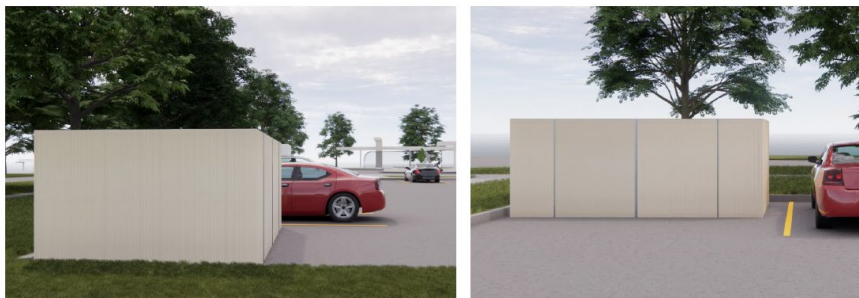

### Signage

[https://inlanc.sharepoint.com/sites/PlanningDept-Boards/Shared Documents/Boards/UDC/Agendas/2026/May 5 Web PDF's/UDR26045\\_MMTC\\_ITEM2.docx](https://inlanc.sharepoint.com/sites/PlanningDept-Boards/Shared Documents/Boards/UDC/Agendas/2026/May 5 Web PDF's/UDR26045_MMTC_ITEM2.docx)



## Summary of Request

This project was previously presented to the Urban Design Committee in May 2024, when the discussion focused on site selection, the various studies and community engagement efforts that shaped the project, impact studies and factors affecting the project area, project funding, and preliminary design visuals. The applicant has now returned with detailed and updated concept drawings for review and final action.

The Multi-Modal Transit Center is a City-led project located in Downtown Lincoln, situated within a Public Use zoning district. The project is receiving federal funding and represents a significant addition to the City's transit infrastructure. While no formal design standards apply to this site, the project occupies a prominent and contextually sensitive location, adjacent to the County-City Building to the north, residential uses to the south, and small-scale office buildings to the east and west. Given the project's civic significance and its relationship to the surrounding context, staff is requesting the Urban Design Committee's review and final action on the following:

- Façade treatment, selection of materials- including considerations of durability and long-term maintenance, and overall color palette;
- Sustainability initiatives incorporated into the building design and site features;
- Landscape design, site furniture, amenities, their contribution to the overall passenger and visitor experience, and the project's interaction with the existing site context;
- Placement of the operations building, bus bays, vehicular parking, and the overall approach to on-site circulation;
- Wayfinding, signage, and legibility of the facility for transit users and the general public; and
- The overall design approach with respect to massing, transparency, and visual connection to the surrounding public realm.

# ATTACHMENT A - Location Map

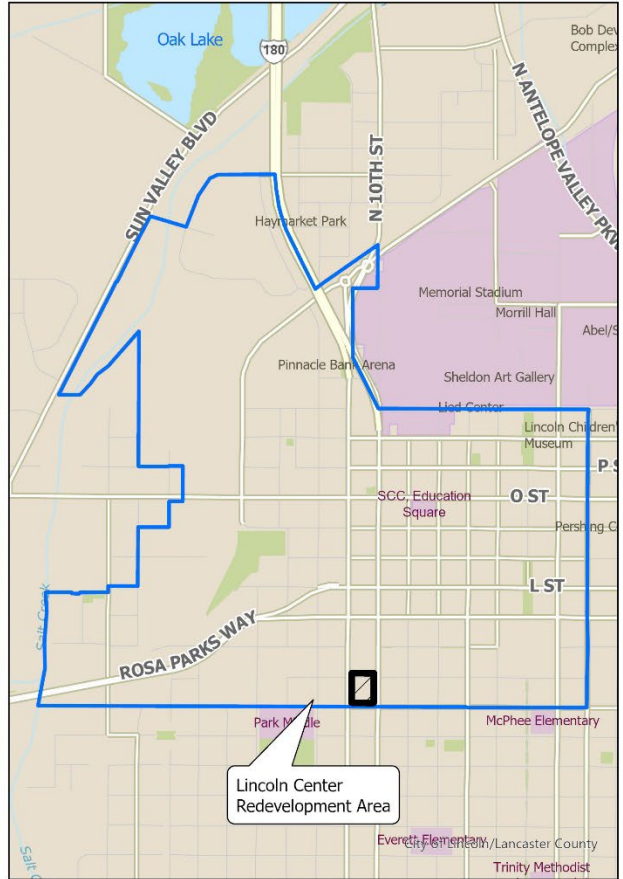
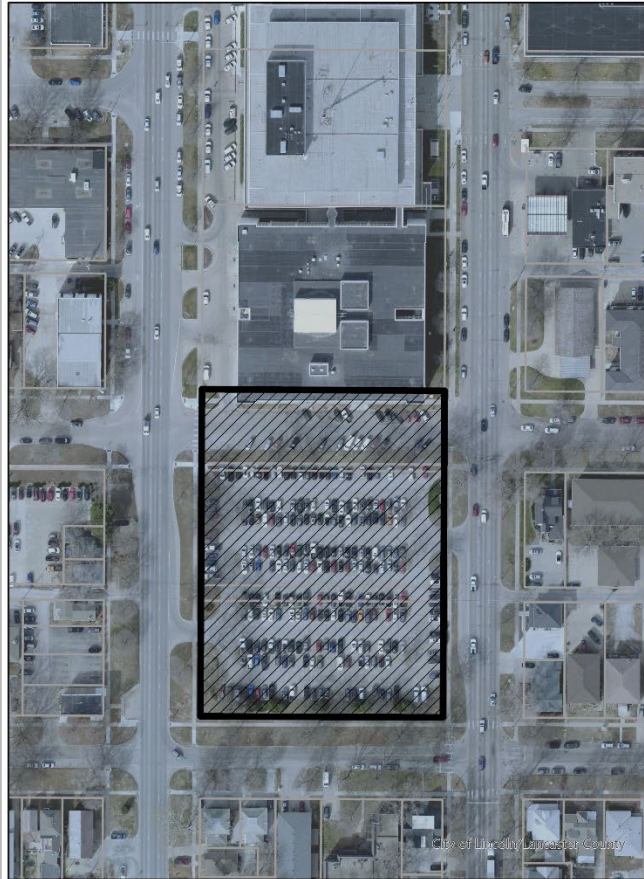

2024 aerial

UDR26045 - 701 S 10th St

Project: 0819ProjectDevRevel1.00\_LocationMaps.aprx  
11/17/2024 10:28:07 AM  
Trinity Methodist  
Lancaster County



transportation **PARK**  
*marrying the experience of a park and transit center*



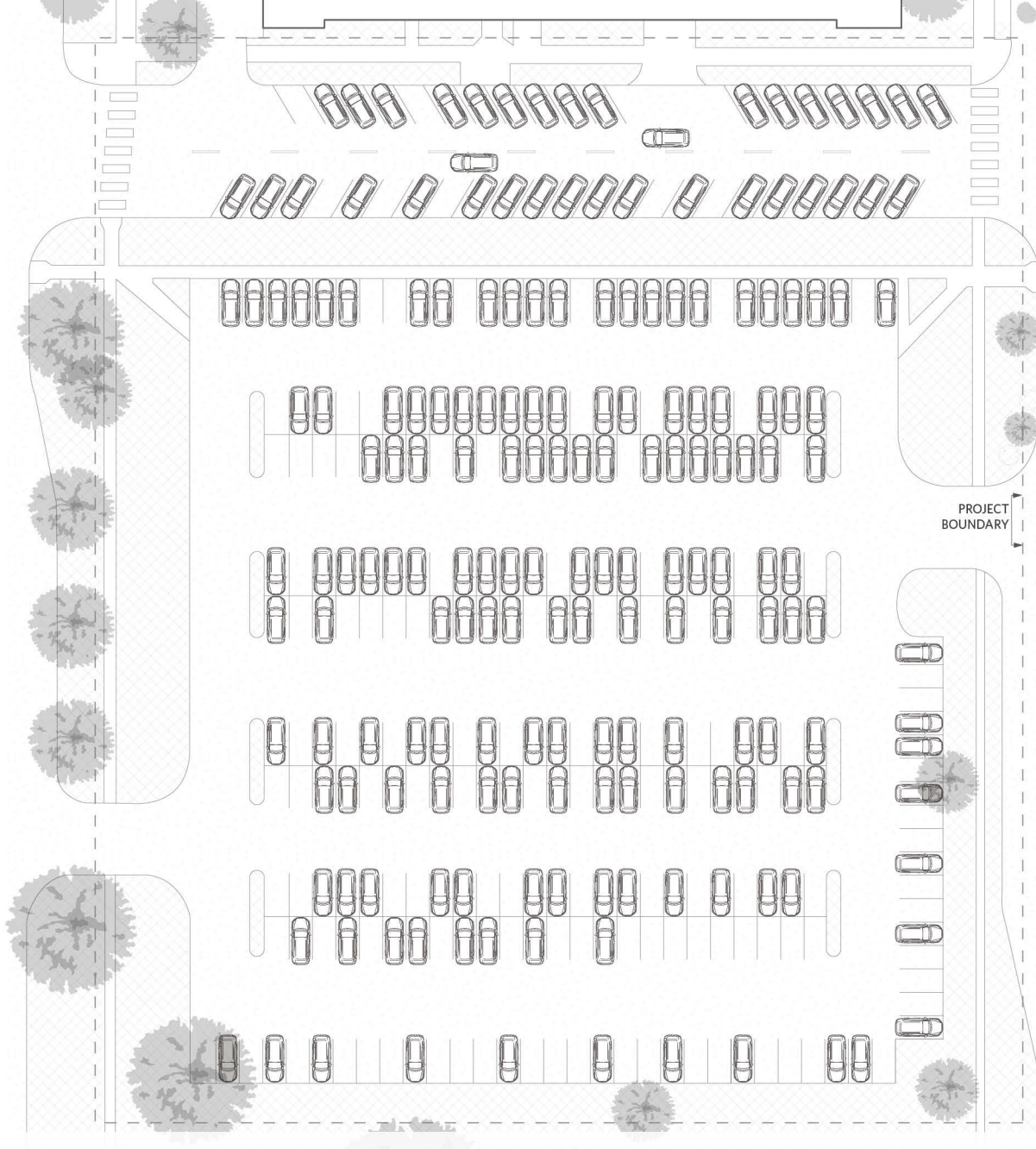

**SITE PLAN**

10' 30' 50'

N

## PAVEMENT

**The task:** Transform an urban, surface parking lot into a multi-modal transit center

Situated on a site which is today a surface parking lot, this proposal brings a multi-modal transit center disguised as a park to the city of Lincoln, NE. The aim is to improve the transit experience, and maximize the public benefit of this much needed public resource.

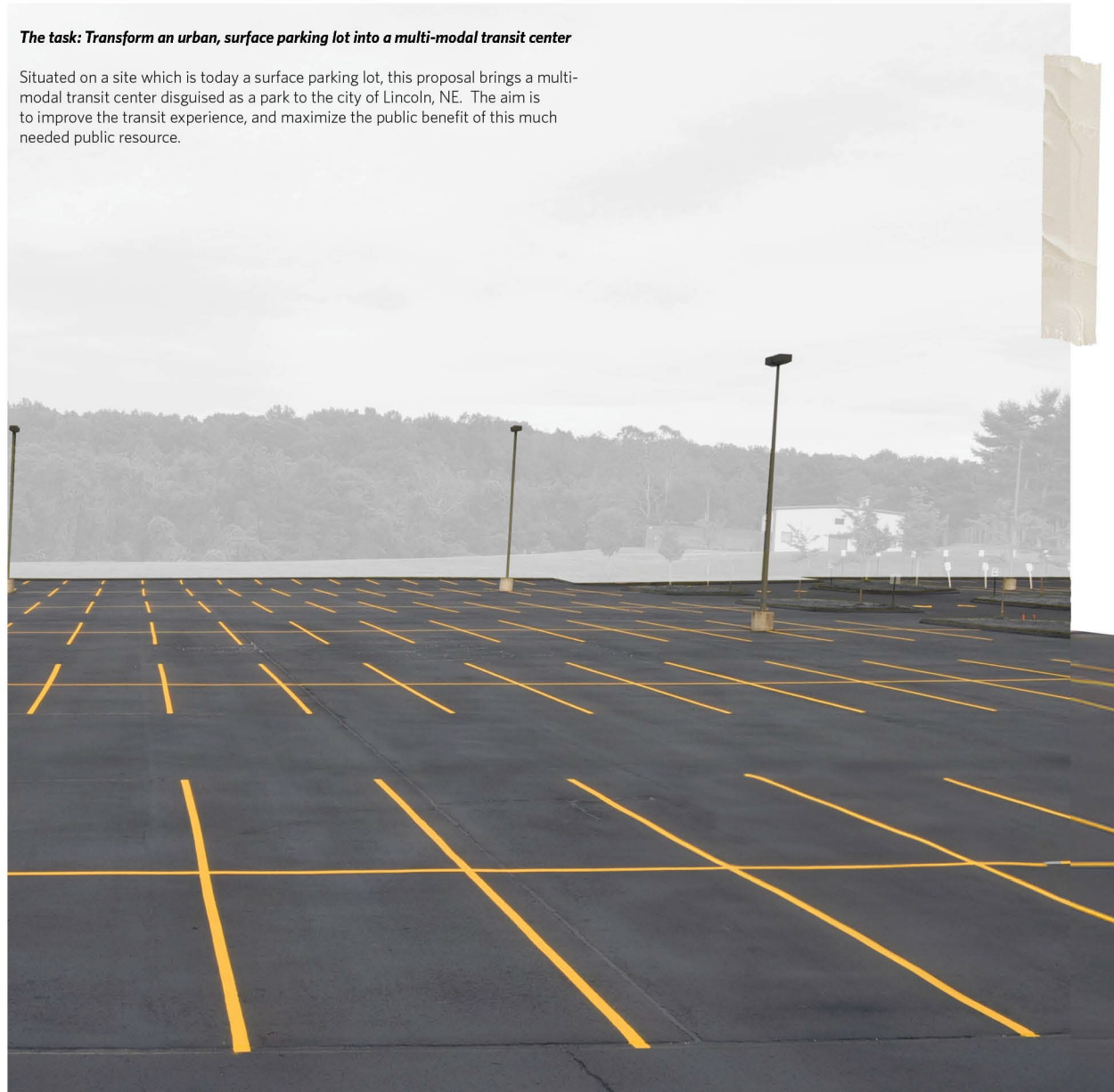

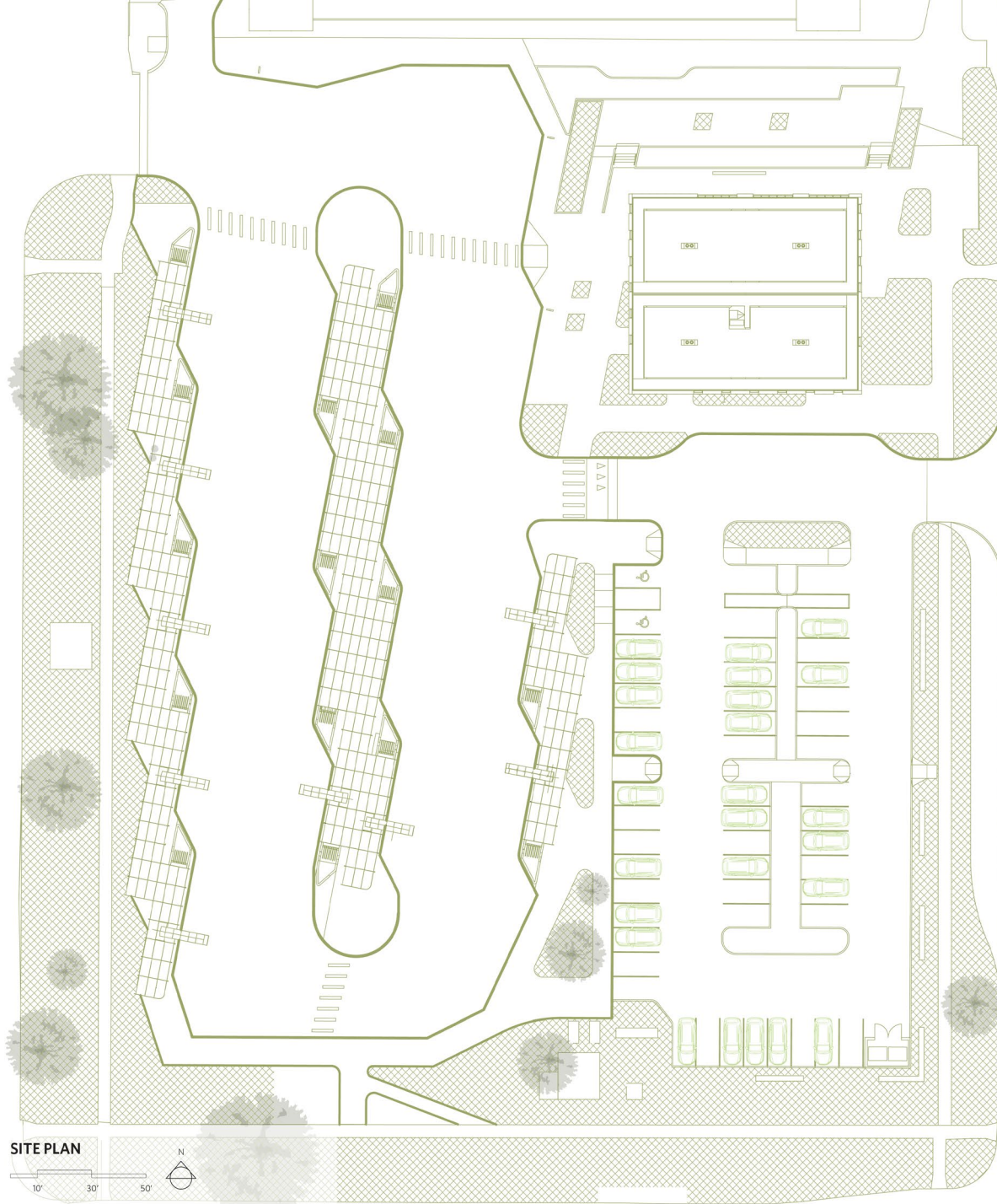

## RK PA~~VE~~MENT

*What if visiting a transit center felt like visiting a park?*

In addition to meeting the base program requirements for the project, this proposal posits that a transit center — a project typology that typically requires a high percentage of impervious pavement — could aspire to offer visitors something more. If a transit center can indeed feel like a park, then perhaps the use of public transportation can not only move riders, but also nourish them along the way.



**Project Principles:**

The development of the Multi-modal Transit Center (MMTC) was guided by the following principles:

1. The MMTC shall support StarTran as an **accessible, affordable, reliable,** and **sustainable** service for Lincoln.
2. The MMTC shall be **safe, universal,** and **accommodating.**
3. The MMTC shall be **climate-smart, prioritize equity,** and facilitate a more climate responsive environment for the entire community.
4. The MMTC shall be **fully integrated** into the downtown multi-modal network.
5. The MMTC shall function as a **gateway** to our downtown and city.
6. The MMTC shall support the **vibrancy** of Lincoln's neighborhoods.
7. The MMTC shall be designed to be **flexible,** and able to respond to future conditions.





olsson

Star Tran Multi-Modal Transit Center

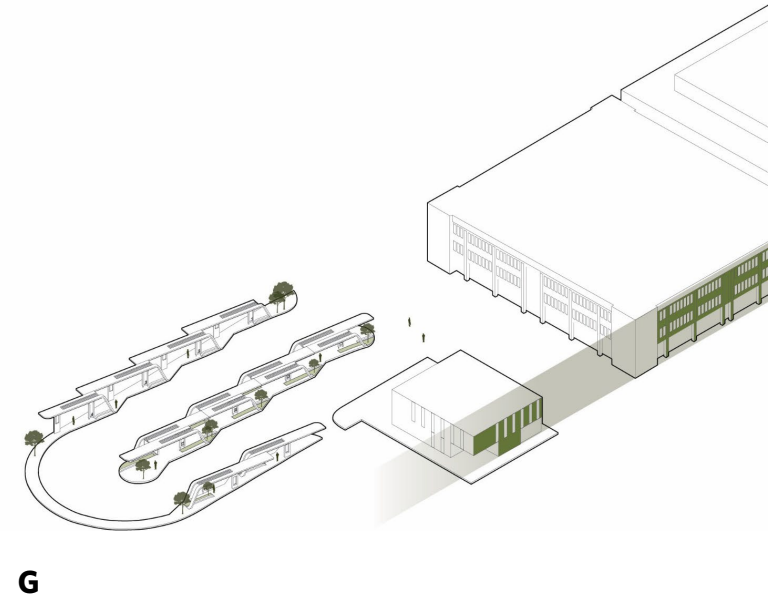
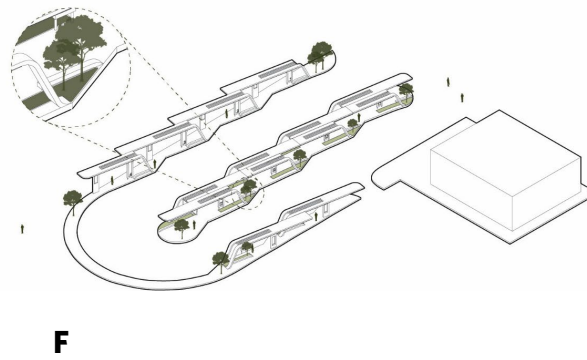
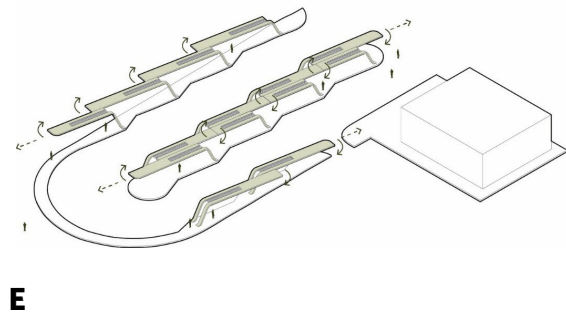
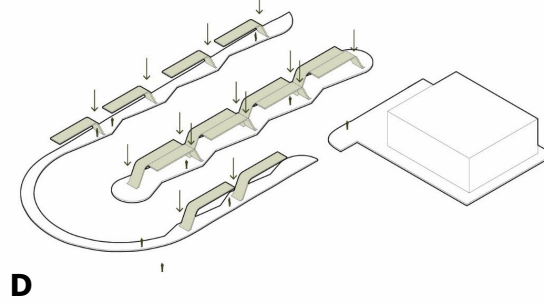
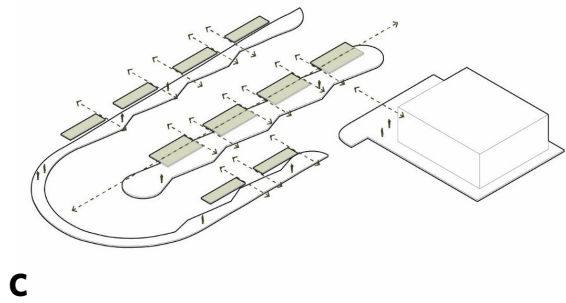
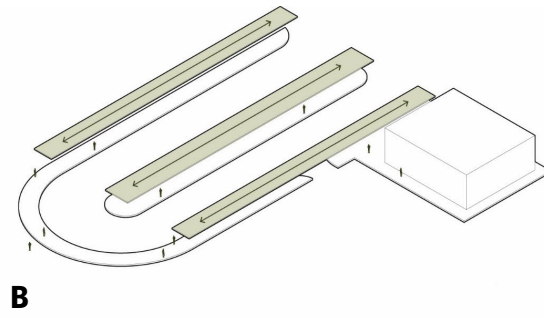
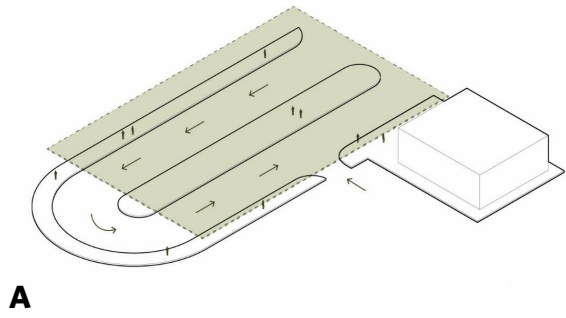

### A Simple Parti:

The configuration of the bus bays and associated canopies is derived from optimal bus movement patterns. The angles in the canopies add an element of deviation from the normalized building geometries.

Meanwhile, the architecture strives to align with its immediate context, offering an adaptation of the rigorous language of the county/city building architecture.

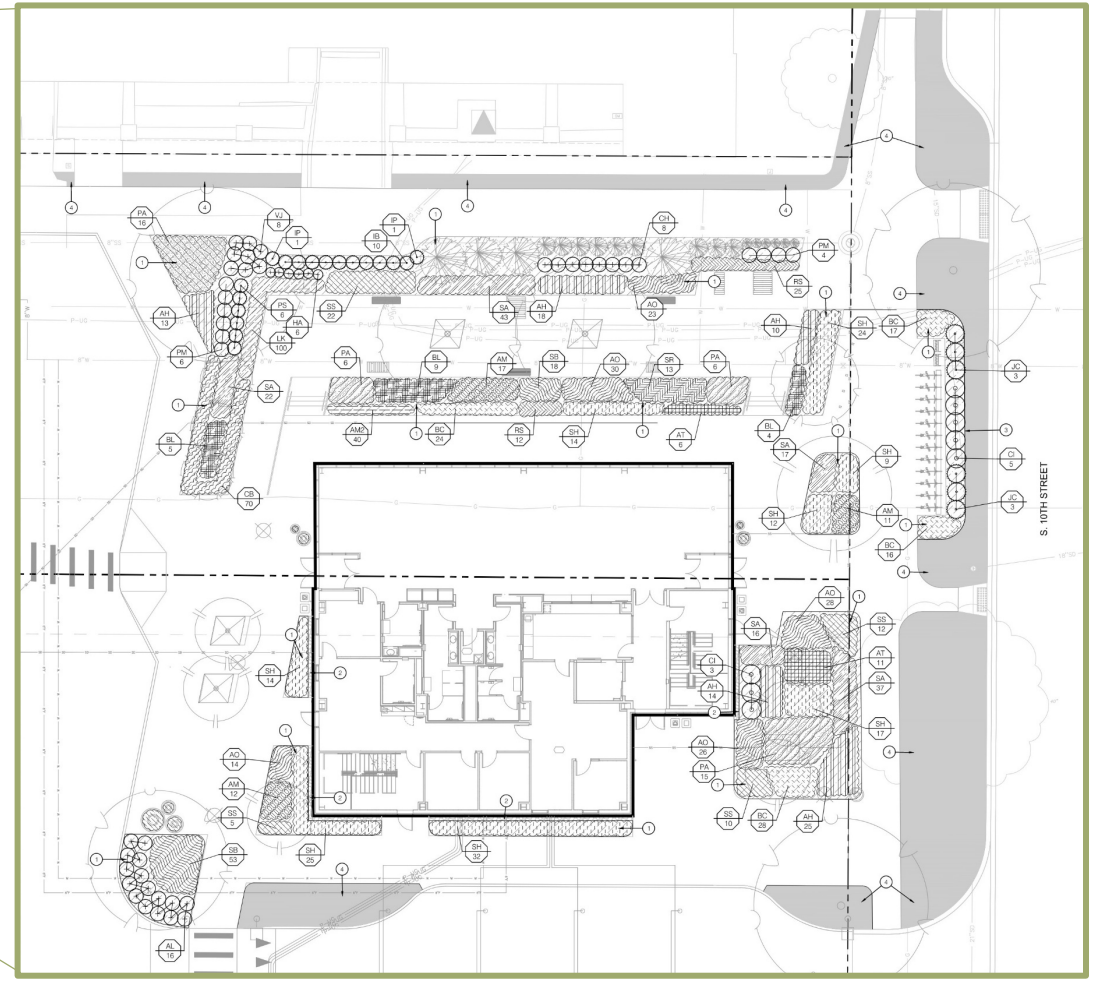
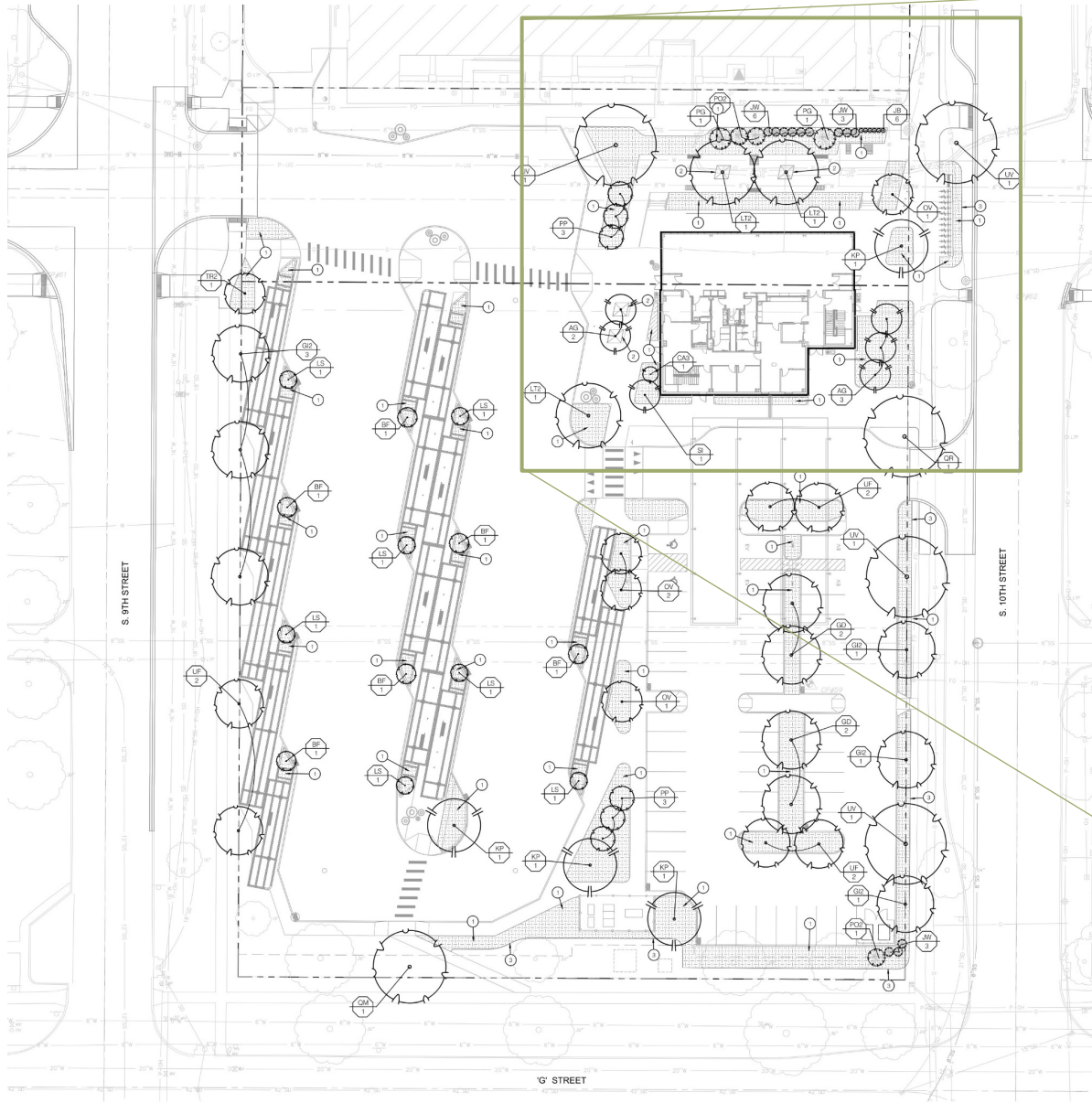

- 1 ELECTRICAL
- 2 MECHANICAL
- 3 DRIVER SUPPORT AREA
- 4 RESTROOM
- 5 SECURITY
- 6 JANITOR
- 7 BREAK ROOM
- 8 TICKETING
- 9 OFFICE
- 10 RETAIL
- 11 WAITING ROOM

**GROUND FLOOR PLAN**

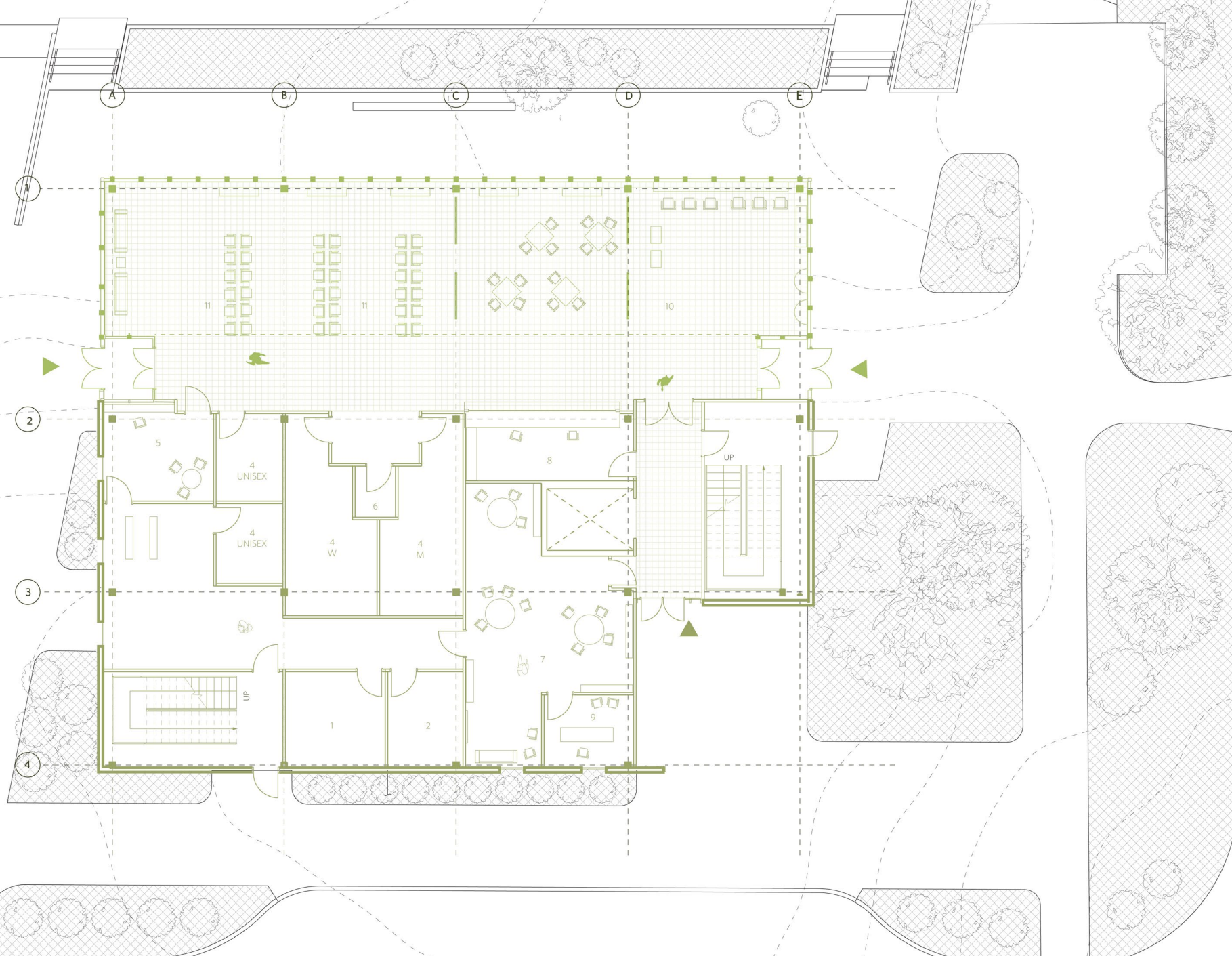
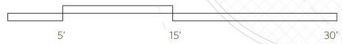

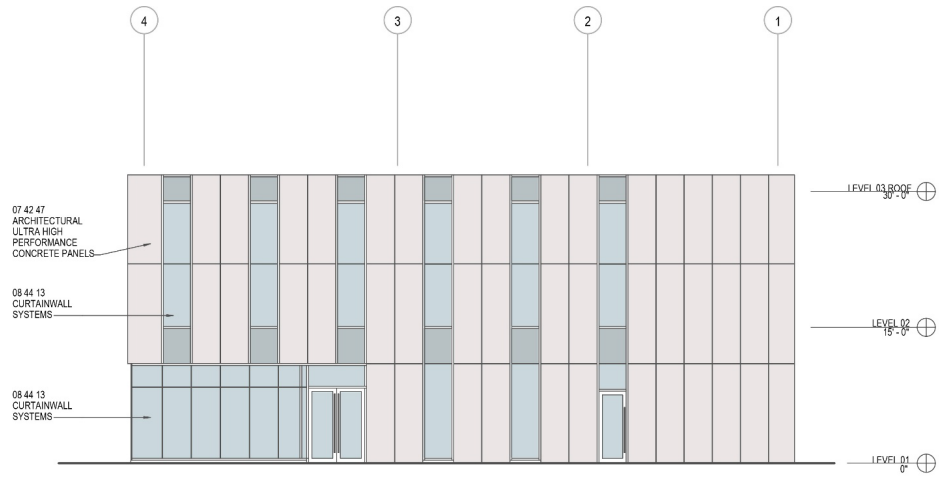

**West Elevation**

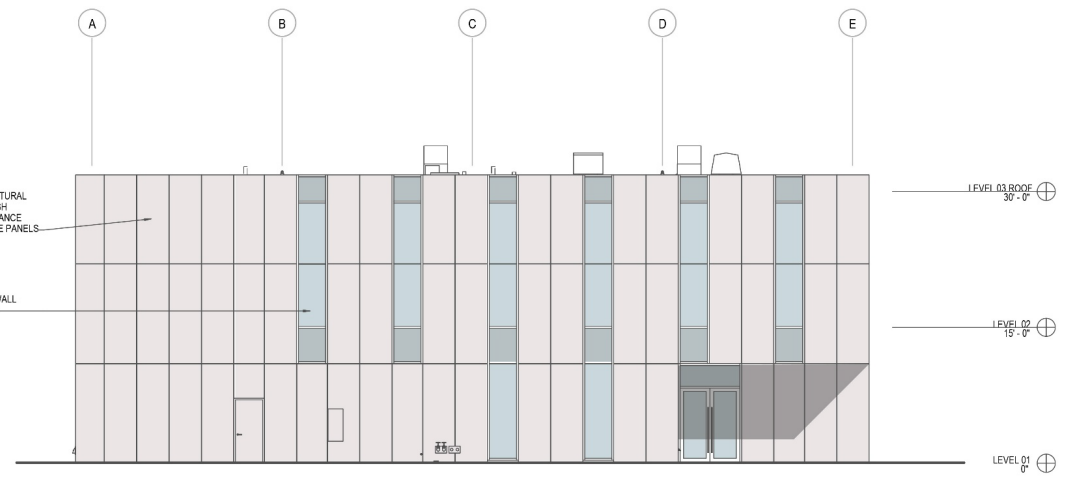

**South Elevation**

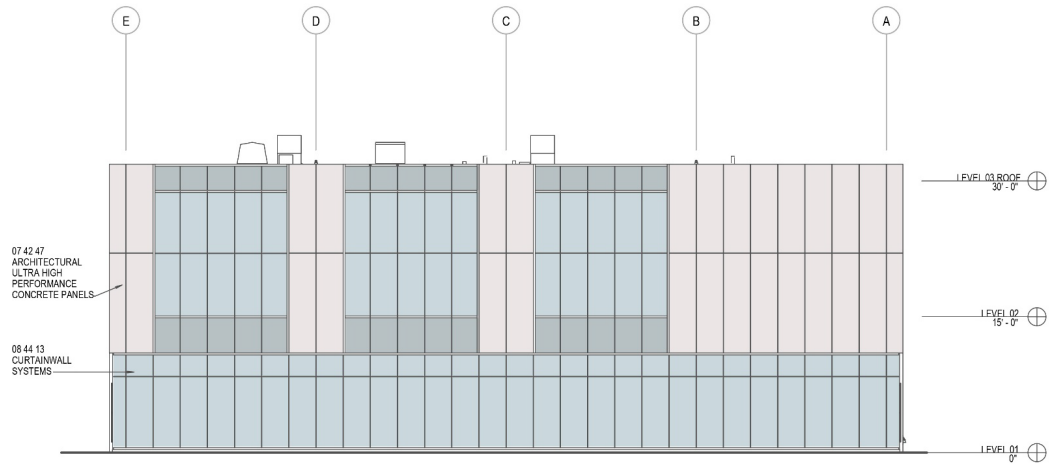

**North Elevation**

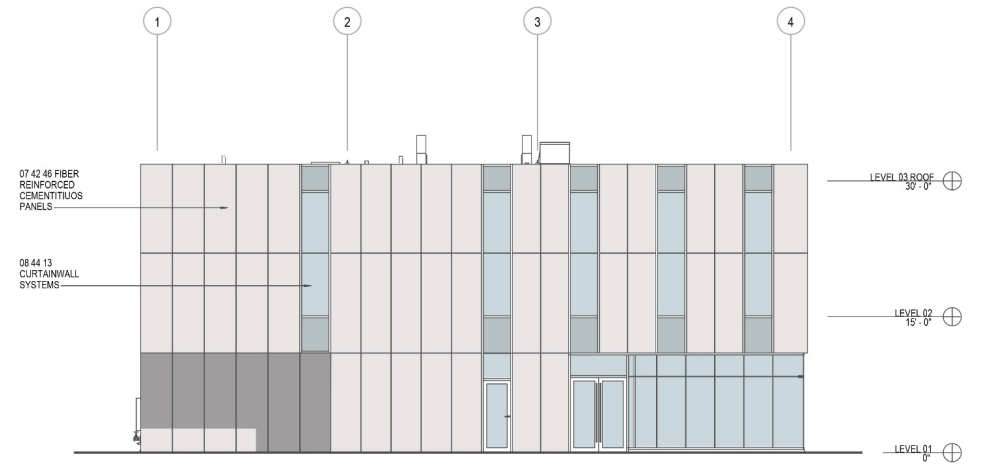

**East Elevation**

**Architectural  
Material Palette**



**Aluminum  
Mullions**  
Dark Bronze



**Exterior UHPC Rain Screen**  
White Finish



**Aluminum Battens & Soffits with  
Wood-look Electrostatic Finish**  
White Ash Finish



olsson

Star Tran Multi-Modal Transit Center

**Landscape**  
Seating Elements



NOMINAL DIMENSIONS

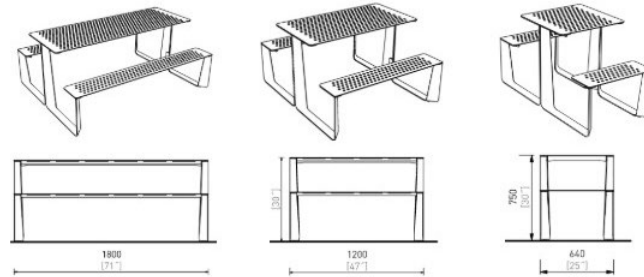
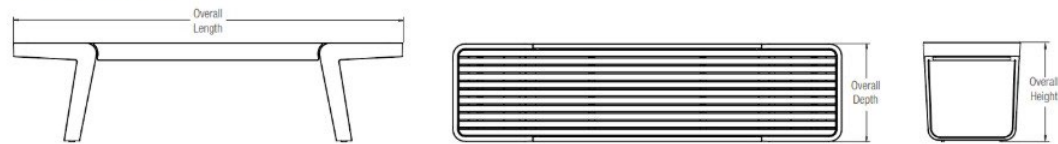

## Landscape:

### Bike and Scooter Storage

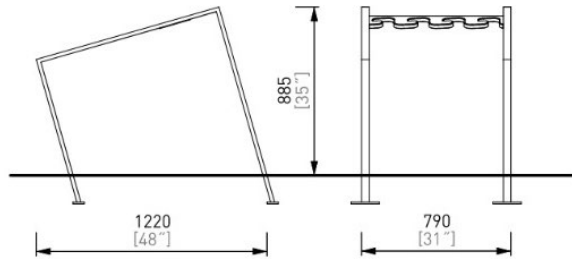

NOMINAL DIMENSIONS

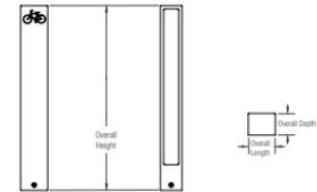

**Landscape**  
Screening



**Landscape**  
Signage





olsson

Star Tran Multi-Modal Transit Center



**Energy Efficiency:**

Sourcing on-site renewables to help offset energy demand

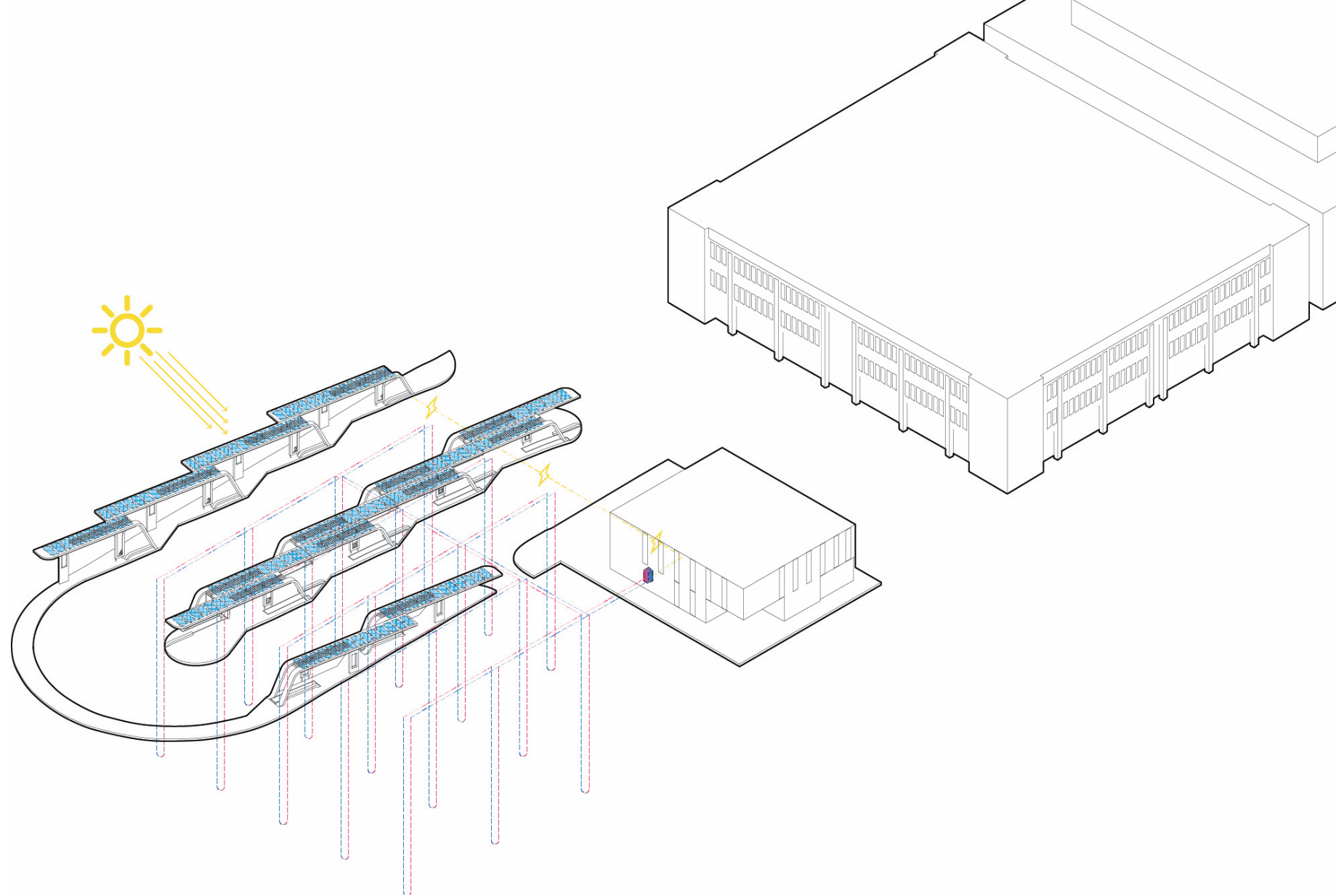

olsson

Star Tran Multi-Modal Transit Center



olsson

Star Tran Multi-Modal Transit Center



olsson

Star Tran Multi-Modal Transit Center



olsson

Star Tran Multi-Modal Transit Center